



Rewarding Learning

**General Certificate of Secondary Education
2024**

Technology and Design

Unit 2

Option C: Product Design

[GTY23]

WEDNESDAY 12 JUNE, MORNING

MARK SCHEME

General Marking Instructions

Introduction

Mark schemes are intended to ensure that the GCSE examinations are marked consistently and fairly. The mark schemes provide markers with an indication of the nature and range of candidates' responses. The mark schemes should be read in conjunction with these general marking instructions.

Assessment objectives

Below are the assessment objectives for **GCSE Technology and Design**.

Candidates must:

- AO1** Recall, select and communicate their knowledge and understanding of Technology and Design in a range of contexts;
- AO2** Apply skills knowledge and understanding, including quality standards in a variety of design contexts. Plan and carry out investigations and making tasks involving an appropriate range of tools, equipment, materials and processes; and
- AO3** Analyse and evaluate evidence, design proposals and outcomes, make reasoned judgements and present conclusions and recommendations.

Quality of candidates' responses

In marking the examination papers, examiners should be looking for a quality of response reflecting the level of maturity which may reasonably be expected of a 16-year-old which is the age at which the majority of candidates sit their GCSE examinations.

Flexibility in marking

Mark schemes are not intended to be totally prescriptive. No mark scheme can cover all the responses which candidates may produce. In the event of an unanticipated answer, examiners are expected to use their professional judgement to assess the validity of answers. If an answer is particularly problematic, then examiners should seek the guidance of the Supervising Examiner.

Positive Marking

Examiners are encouraged to be positive in their marking, giving appropriate credit for what candidates know, understand and can do rather than penalising candidates for errors or omissions. Examiners should make use of the whole of the available mark range for any particular question and be prepared to award full marks for a response which is as good as might reasonably be expected of a 16-year-old GCSE candidate.

Awarding zero marks

Marks should only be awarded for valid responses and no marks should be awarded for an answer which is completely incorrect or inappropriate.

Types of mark schemes

Mark schemes for tasks or questions which require candidates to respond in extended written form are marked on the basis of levels of response which take account of the quality of written communication.

Other questions which require only short answers are marked on a point for point basis with marks awarded for each valid piece of information provided.

Levels of response

Tasks and questions requiring candidates to respond in extended writing are marked in terms of levels of response. In deciding which level of response to award, examiners should look for the ‘best fit’ bearing in mind that weakness in one area may be compensated for by strength in another. In deciding which mark within a particular level to award to any response, examiners are expected to use their professional judgement.

Marking calculations

In marking answers involving calculations, examiners should apply the “own figure rule” so that candidates are not penalised more than once for a computational error.

Quality of written communication

Quality of written communication is taken into account in assessing candidates’ responses to all tasks and questions that require them to respond in written form. These tasks and questions are marked on the basis of levels of response. The description for each level of response includes reference to the quality of written communication.

For conciseness, quality of written communication is distinguished within levels of response as follows:

Band 1: Quality of written communication is basic.





Band 2: Quality of written communication is limited.

Band 3: Quality of written communication is satisfactory.

Band 4: Quality of written communication is good.

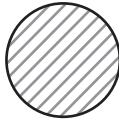
In interpreting these level descriptions, examiners should refer to the more detailed guidance provided in the relevant question in the mark scheme.

1 (a)

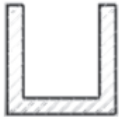
Cross section profile	Cross section name
	Angle
	Round bar
	I-shaped section
	Sheet
	Tube
	U-shaped channel

(5 × [1])

[5]

All relevant, valid responses will be given credit.

- (b) (i) $30 \times 25 = 750$ [1]
 $21 \times 18 = 378$ [1]
 $750 - 378 = 372$ [1]

- or** $30 \times 7 = 210$ [1]
 $9 \times 18 = 162$ [1]
 $210 + 162 = 372$ [1]

- or** $9 \times 25 = 225$ [1]
 $7 \times 21 = 147$ [1]
 $225 + 147 = 372$ [1]

(3 × [1])

[3]

- (ii) Extrusion

[1]

- (c) (i) Tolerance is the permissible limit of variation in size

[1]

- (ii) Testing a number of the products [1] to ensure the product is within tolerance. [1]

(2 × [1])

[2]

All relevant, valid responses will be given credit.

AVAILABLE MARKS

12

2 (a) (i)

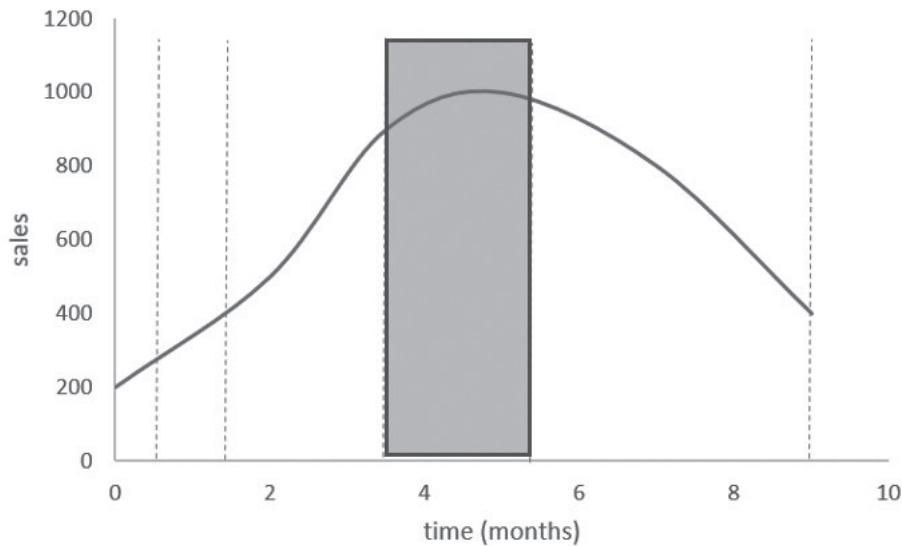

[1]

(ii) Inception/development

Introduction

Growth

Decline

(4 × [1])

[4]

(b) The maturity stage of the product life cycle shows that the toy sales peak [1] and then slow. [1]

(2 × [1])

[2]

All relevant, valid responses will be given credit.

(c) Any **three** from:

- Price can be lowered for customers/stockists
- Identify new markets,
- Different advertising or sales promotion techniques can prolong the life of the product, giving it a new image
- Change the packaging design

(3 × [1])

[3]

All relevant, valid responses will be given credit.

(d) Definition

Built-in obsolescence is a process of designing products to require periodic replacement. [1]

Explanation

Any **two** from:

The toy company is designing the toy that will run out of power within a relatively predictable period of time. [1] This encourages the consumer to discard it and buy the same toy again or a slightly newer version, [1] thus, increasing sales. [1]

(2 × [1])

[3]

All relevant, valid responses will be given credit.

AVAILABLE
MARKS

13

3 (a) (i) 10

[1]

(ii)

Time (minutes) \ Task	5	10	15	20	25	30	35
Polishing							
Marking out and gluing							
Wet and dry abrasive							
Filing and drilling							

Durations marked correctly as shown (4 × [1])

Correct durations in all rows [1]

[5]

(b) Any **two** from:

- Steel rule
- Spring dividers
- Try square
- Template/radius curve
- Pencil/OHP pen

(2 × [1])

[2]

All relevant, valid responses will be given credit.

4 (a) Any **two** from:

- Doesn't corrode
- Hygienic/sterile/easy to clean/stain resistant
- Durable
- Strong
- Hard

(2 × [1])

[2]

All relevant, valid responses will be given credit.

(b) (i) Data on human body size and shape.

[1]

(ii) Any **two** from:

- Knurled/textured grip
- Size of tools
- Slimline
- Length to allow for appropriate use/leverage
- Angle of tool

(2 × [1])

[2]

All relevant, valid responses will be given credit.

(c) (i) Nitinol

[1]

(ii) Returns to its original shape. [1] This aligns the teeth. [1]

(2 × [1])

[2]

AVAILABLE
MARKS

8

8

5 (a) Softwood [1]

(b) (i) $3 \times 60 = 180$ [1] $\times 5 = 900$ [1]
 or $60 \times 5 = 300$ [1] $\times 3 = 900$ [1]
 or $3 \times 5 = 15$ [1] $\times 60 = 900$ [1]
 (2 \times [1]) [2]

(ii) $16 \times 8 = 128$ [1] $\times 5 = 640$ [1] + 900 [1] = 1540 [1]
 or $16 \times 5 = 80$ [1] $\times 8 = 640$ [1] + 900 [1] = 1540 [1]
 or $8 \times 5 = 40$ [1] $\times 16 = 640$ [1] + 900 [1] = 1540 [1]
 (4 \times [1]) [4]

(c) Possible solutions could focus on:

- Caster wheels platform
- Tripod trolley

The design features are:

- The barrel can be easily moved using the holder
- The barrel is supported securely by the holder
- The holder allows for water drainage

Response Type	Description	Mark to award
When a response is not worthy of credit, a [0] mark should be awarded.		
Basic [1]–[2]	The candidate attempts to produce a design. The quality of sketch(es) is very basic. Where annotation is present it is basic and lacking in technical vocabulary and specialist terms.	[1]
	The candidate produces a basic design. The design attempts to consider at least 1 of the design features. The quality of sketch(es) is basic. Where annotation is present it is basic and lacks the use of technical vocabulary and specialist terms.	[2]
Limited [3]–[4]	The candidate produces a limited design. The design considers at least 1 of the design features. The quality of sketch(es) is limited. Where annotation is present it is limited and lacks the use of technical vocabulary and specialist terms.	[3]
	The candidate produces a limited design. The design considers at least 2 of the design features. The quality of sketch(es) is limited. Where annotation is present it is limited but uses some technical vocabulary and specialist terms.	[4]
Satisfactory [5]–[6]	The candidate produces a satisfactory design. The design considers at least 2 of the design features. The sketch(es) is satisfactory. Annotation is satisfactory and uses some technical vocabulary and specialist terms.	[5]
	The candidate produces a satisfactory design. The design incorporates at least 2 of the design features. The sketch(es) is satisfactory. Annotation is satisfactory and generally uses technical vocabulary and specialist terms.	[6]

AVAILABLE MARKS

Good [7]–[8]	The candidate produces a good design. The design incorporates 2 or 3 of the design features. Good clear sketch(es) linked to good annotation generally using technical vocabulary and specialist terms.	[7]
	The candidate produces a very good design. The design incorporates at least 3 of the design features with some detail. Very good clear sketches linked to good annotation generally using technical vocabulary and specialist terms.	[8]
Excellent [9]–[10]	The candidate produces an excellent design. The design fully incorporates all the design features. Excellent clear sketch(es) and annotation generally using technical vocabulary and specialist terms.	[9]
	The candidate produces an excellent design. The design fully incorporates all the design features showing excellent detail and clarity. Excellent clear sketch(es) and annotation using technical vocabulary and specialist terms.	[10]

[10]

AVAILABLE
MARKS

17

6 (a) Indicative content:

- The company will be able to sell the product at cheaper costs. [1] There is increased availability and variety of products. [1]
- Cultural diversity in companies will improve [1] as people move around the world following employment. [1]
- It will lessen skill gaps [1] in countries as there is a constant flow of technical skills from one region of the world to another. [1]
- Company may move due to more available resources [1] such as local materials/workforce/environment. [1]
- The company can trade across nations [1] and therefore corresponding economic success. [1]
- There will be the constant flow of ideas and skills across the company [1] and improvement in workforce skills/product outcomes. [1]
- Many manufacturing industries are constantly chasing increased profits. [1] They often move to the source of cheap labour. [1]
- Negative outcomes for company such as pollution/environmental damage [1] could damage company reputation. [1]
- Different regulations across regions/nations [1] will affect H & S of worker/corporate costs. [1]
- Larger companies dominate the marketplace [1] making it difficult for smaller companies to sell products/profit. [1]

(3 × [2])

[6]

All relevant, valid responses will be given credit.

(b) Any three from:

- CAD facilities may be located centrally
- Drawings may be sent electronically to the appropriate manufacturing sites
- Drawings could easily be adapted to meet local demands and standards

- The CAD facilities may be located where there is availability of the required specialisms.

(3 × [1])

[3]

AVAILABLE
MARKS

9

All relevant, valid responses will be given credit.

7 (a) (i) Any **two** from:

- Lightweight
- Weather resistant
- Withstand extreme temperatures
- Easily shaped/malleable

(2 × [1])

[2]

(ii) Any **three** from:

- Reference to accuracy of hole patterns/spacing/layouts
- Reference to accuracy of the hole sizes
- Each sheet pattern can be manufactured quickly/faster/more efficiently
- Reference to elimination of human error
- Repeatability

(3 × [1])

[3]

All relevant, valid responses will be given credit.

(iii) Any **two** from:

- Reduces weight
- To protect the flame from wind
- To allow the flame to be visible from the sides of the torch

(2 × [1])

[2]

All relevant, valid responses will be given credit.

(iv) Any **two** from:

- Tapered shape.
- Material is lightweight.
- The torch is long.
- The handle is a suitable distance from the flame.
- Holes for grip.

(2 × [1])

[2]

All relevant, valid responses will be given credit.

(b) (i) Edward Barber [1] and Jay Osgerby [1]

[2]

(ii) Any **two** from:

- Loop Table
- Murano glassmakers Venini
- Tip Ton chair
- Lanterne-Marine
- Port Lamp
- Wind Installation
- Tab lamp

(2 × [1])

[2]

All relevant, valid responses will be given credit.

13

8 The design solution should show evidence of the following features:

- Good quality annotated sketches giving consideration to line, shape, form and proportion.
- The height of the stand should be easily adjusted to suit the needs of the user.
- The sheet music should be securely supported and clearly visible when the stand is in use.
- The stand should be freestanding and stable, on the floor, when in use.
- Be aesthetically pleasing and have appropriate surface finish.
- Identify and justify the selection and thickness of materials.
- Identify and justify the main manufacturing techniques used in the design's construction.
- Include three key dimensions.

Quality of written communication will be assessed in this question.

	Design features	Response Band	Description	Mark to award
	When a response is not worthy of credit in a section, a [0] mark should be awarded.			
A	Good quality annotated sketches giving consideration to line, shape, form and proportion.	[1]–[4]	Basic sketch conveying little detail. Basic annotation.	[1]
			Limited sketch conveying some detail. Limited annotation using limited technical vocabulary and limited specialist terms.	[2]
			Satisfactory sketch conveying most information. Satisfactory annotation using some technical vocabulary and some specialist terms.	[3]
			Good sketch giving consideration to all the information. Good annotation using technical vocabulary and specialist terms.	[4]
B	The height of the stand should be easily adjusted to suit the needs of the user.	[1]–[2]	Unrefined solution with some reference to a method of height adjustment.	[1]
			Refined solution giving clear method of height adjustment and securing the stand at the correct height.	[2]
C	The sheet music should be securely supported and clearly visible when the stand is in use.	[1]–[2]	Inappropriate method of holding the sheet music/position of the sheet music does not consider visibility for the user.	[1]
			Solution to position the sheet music securely considering visibility for the user.	[2]

D	The stand should be freestanding and stable, on the floor, when in use.	[1]–[2]	Freestanding design solution with some consideration of stability on the floor when in use.	[1]
			Freestanding design solution that is clearly stable on the floor when in use.	[2]
E	Be aesthetically pleasing and have appropriate surface finish.	[1]–[2]	Unrefined solution with little consideration given to aesthetics and finish.	[1]
			Refined solution, consideration given to aesthetics and suggested finish.	[2]
F	Identify and justify the selection and thickness of materials.	[1]–[2]	Reference to the selection of material/materials with little consideration given to the design of the music stand. Limited use of technical vocabulary and limited specialist terms.	[1]
			Reference to the selection of an appropriate material/materials given for the design of the music stand. Good use of technical vocabulary and specialist terms.	[2]
G	Identify and justify the main manufacturing techniques used in the design's construction.	[1]–[4]	Basic detail of main manufacturing techniques shown/discussed. Basic annotation.	[1]
			Limited detail of main manufacturing techniques shown/discussed. Limited annotation using limited technical vocabulary and limited specialist terms.	[2]
			Satisfactory detail of main appropriate manufacturing techniques shown/discussed. Satisfactory annotation using some technical vocabulary and some specialist terms.	[3]
			Good detail of main appropriate manufacturing techniques shown/discussed. Good annotation using technical vocabulary and specialist terms.	[4]
H	Include three key dimensions.	[1]–[2]	Reference to three key dimensions.	[1]
			Reference to three key dimensions which are appropriate/realistic.	[2]

[20]

Total

AVAILABLE MARKS

20

100